

SECTION A-A

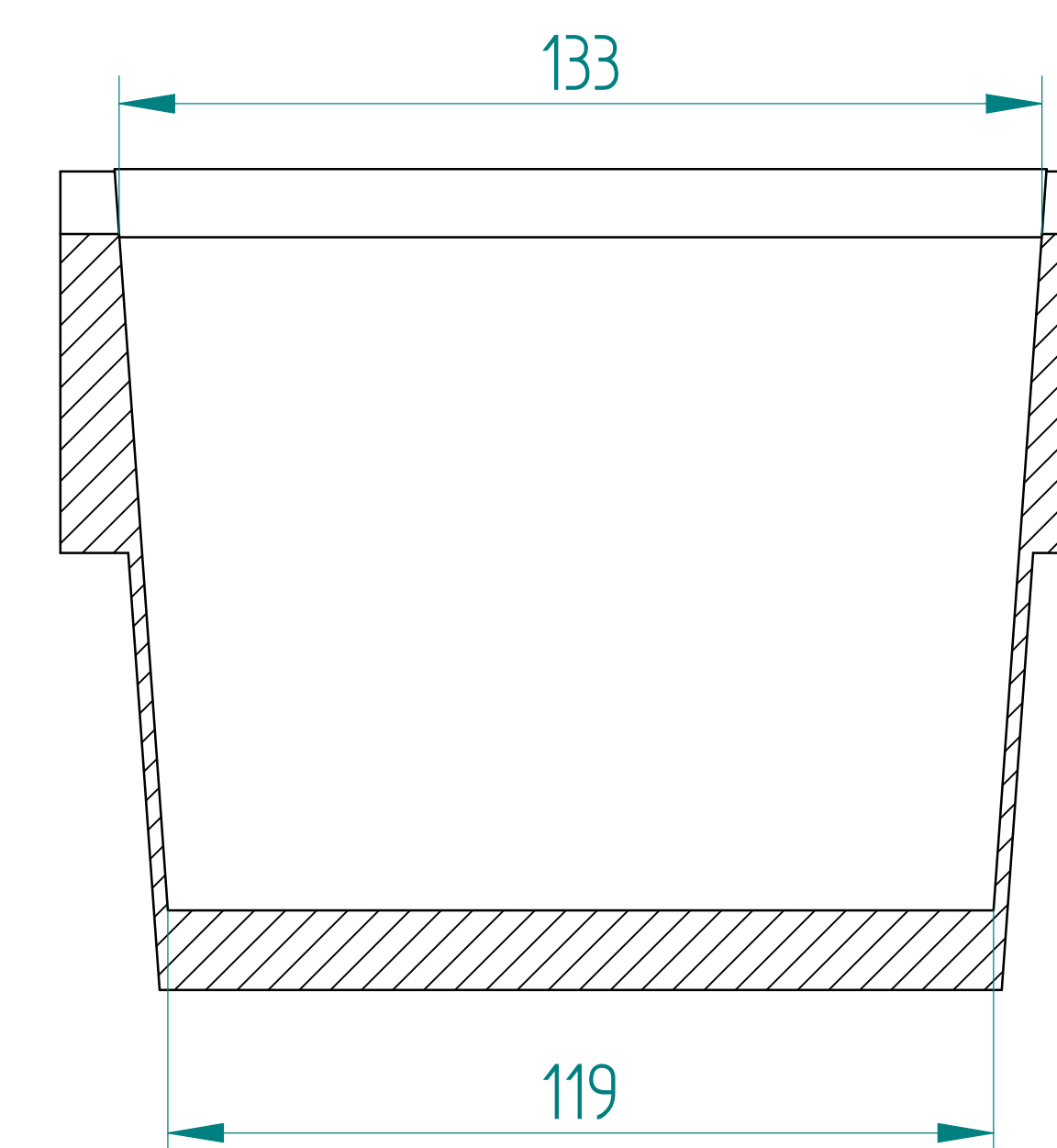

SECTION B-B

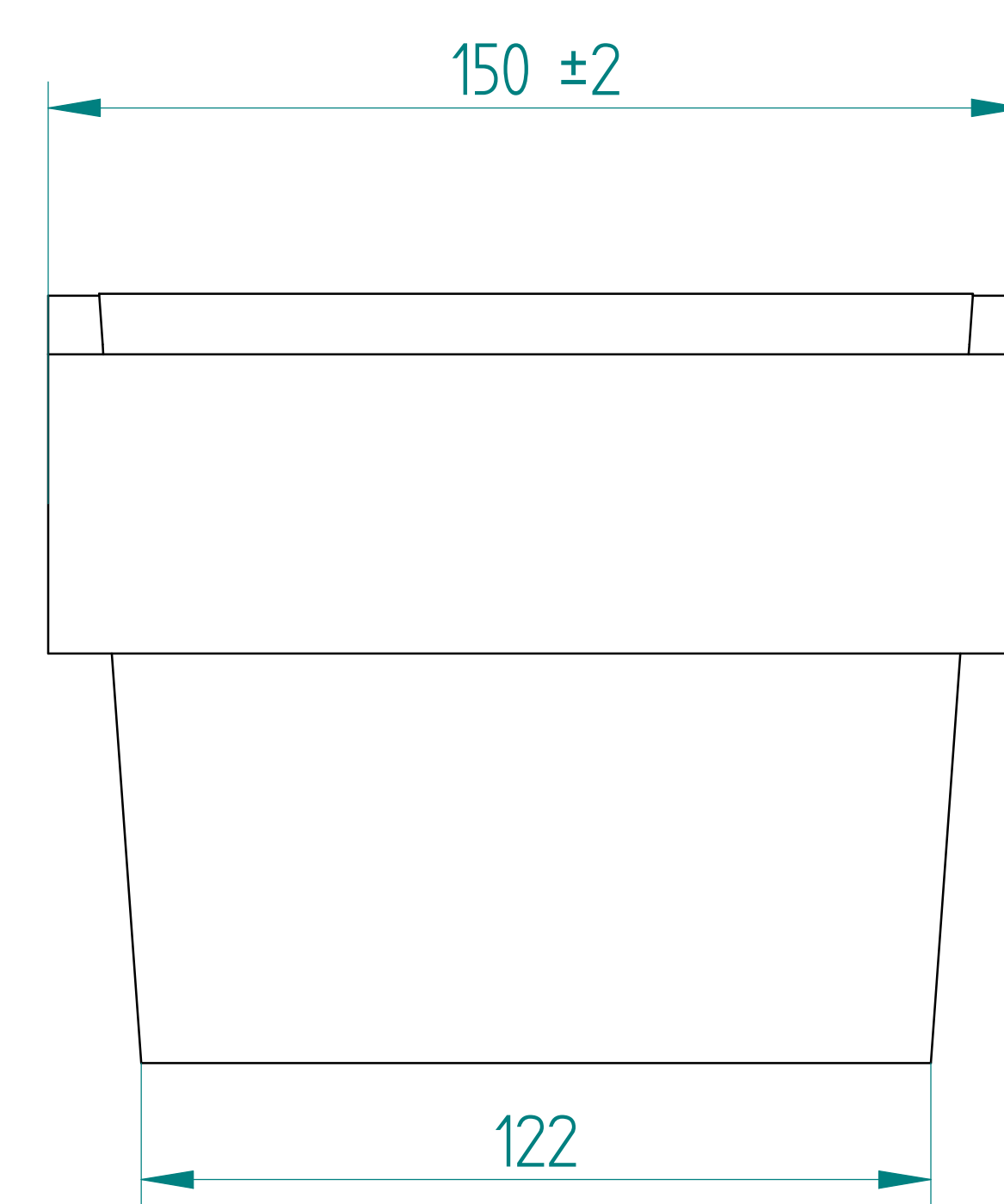
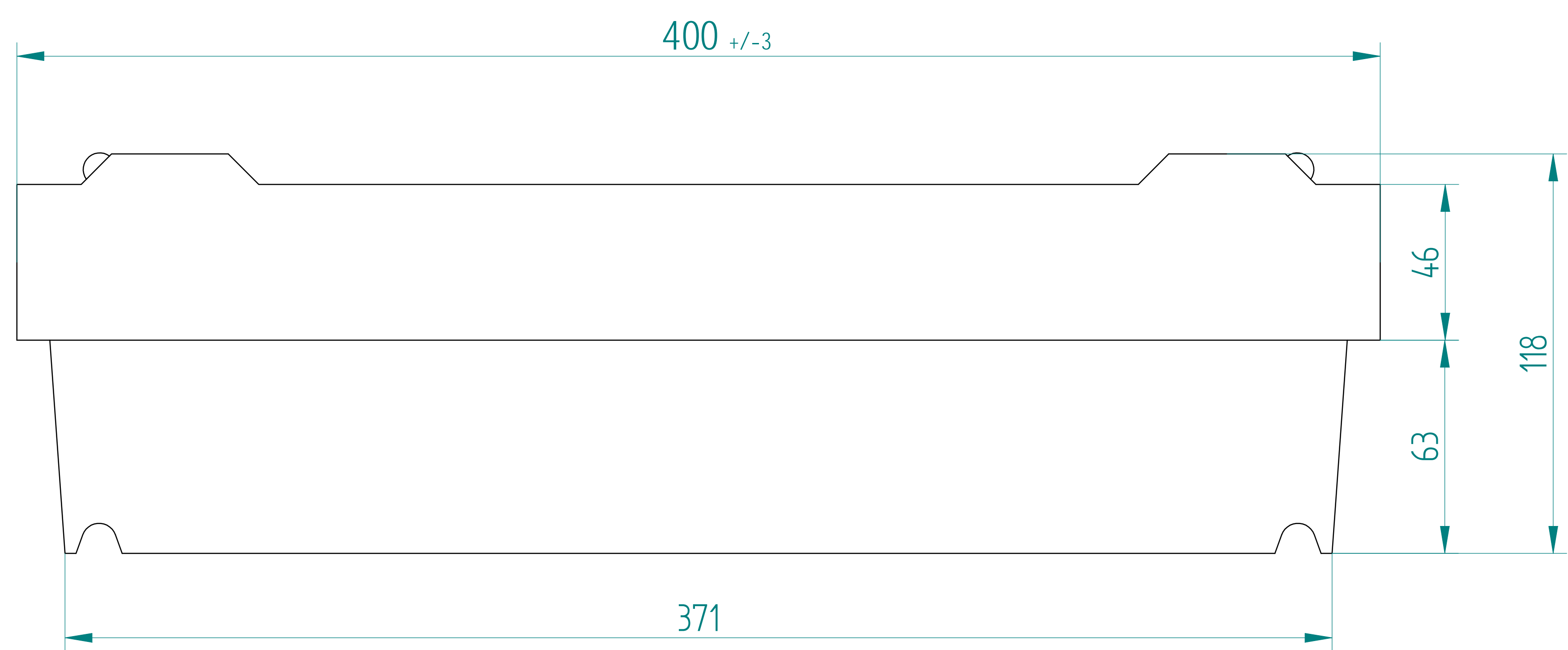
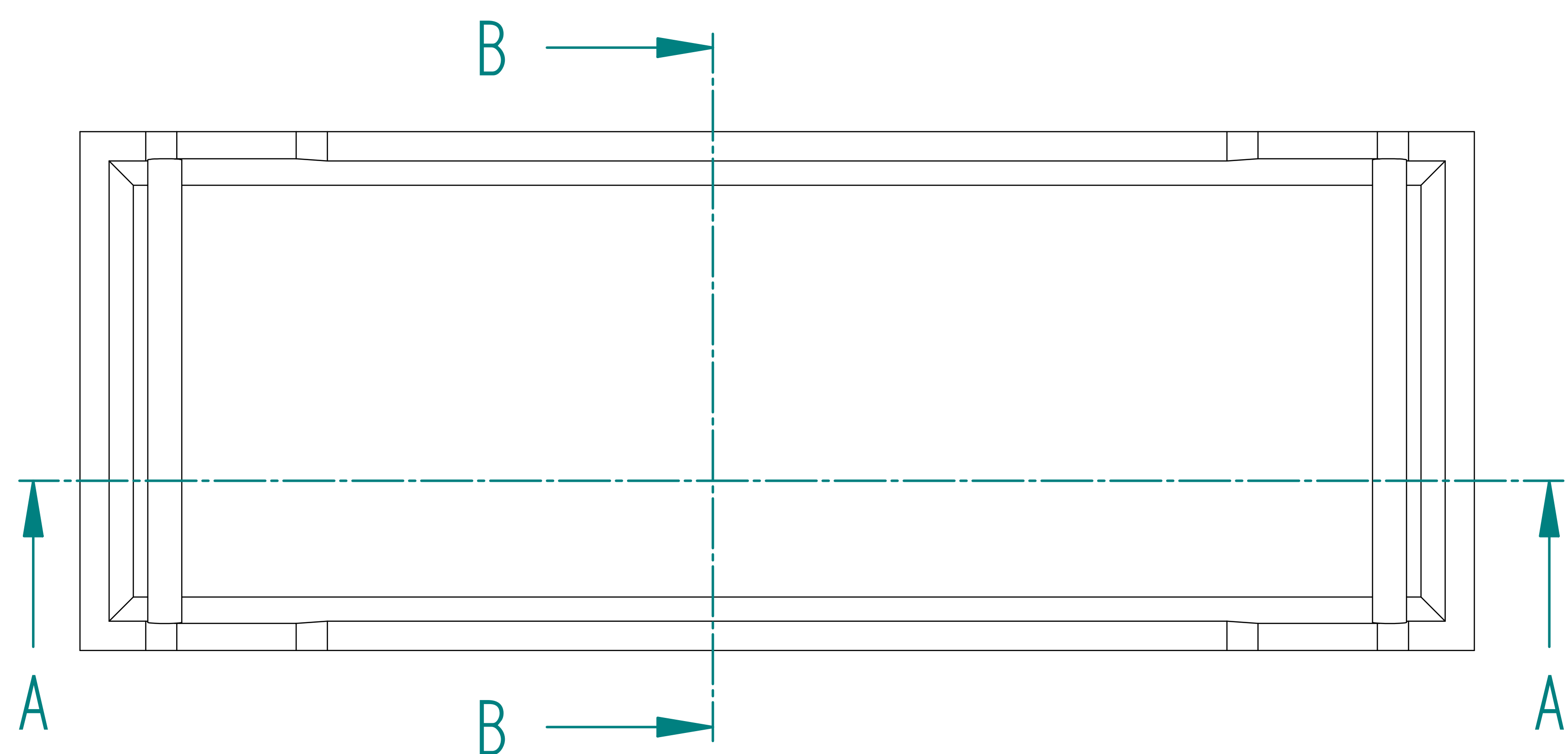
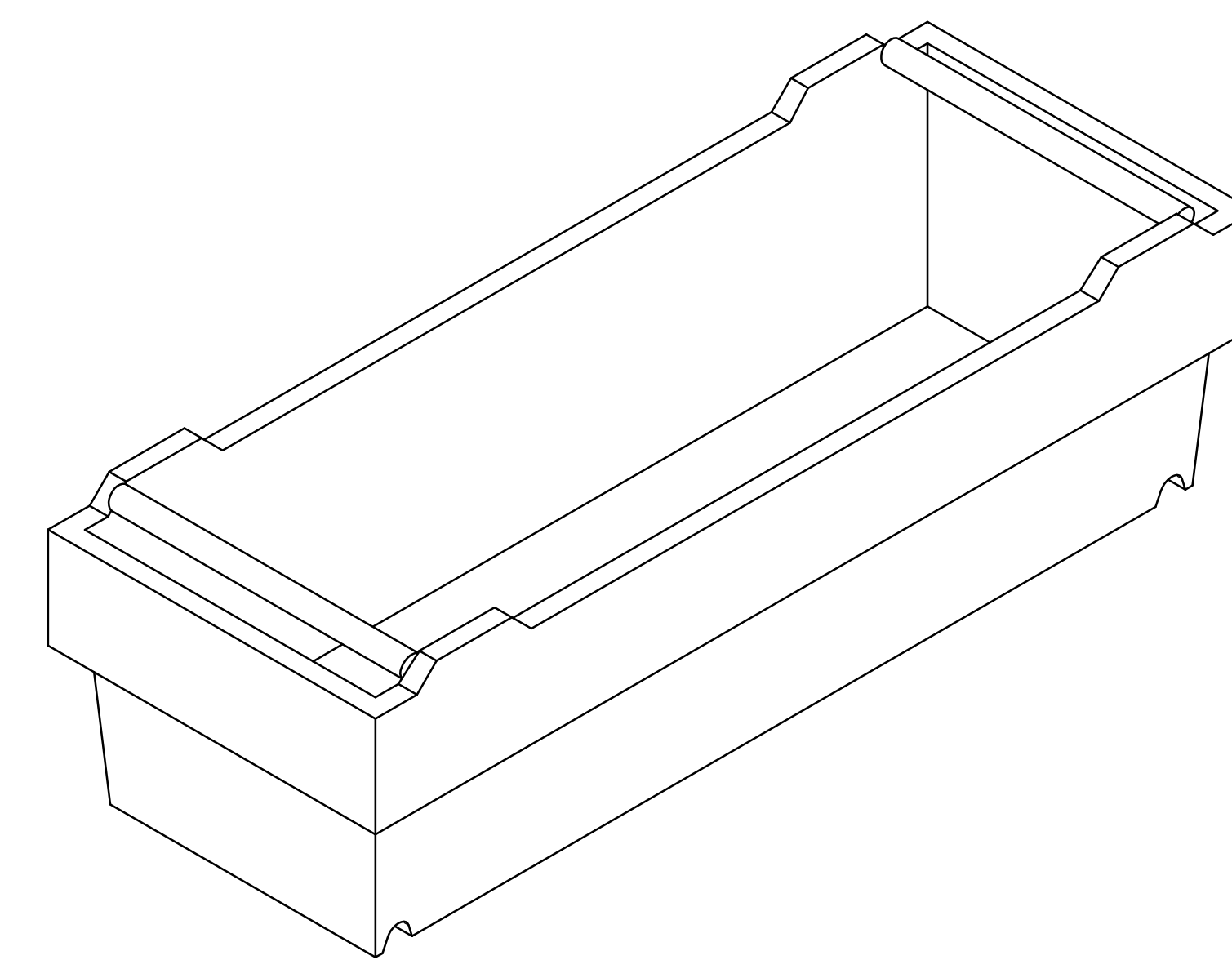

Filename: B6-400-150-118.dft
For other dimensions refer to 3D-file: B6-400-150-118.par

| | | | | | |
|--|----------|-----------|------------------|-------------------|---------|
| Revision | | Date | | Designer | |
| Error: No reference | | | | | |
| General wall thickness | mm | Material | Weight | Project No. | |
| General Draft | | Designer | Date | Scale | Format |
| General Rib thickness | mm | Check | Date | Projection method | Format |
| Unless otherwise specified, use radius R1 | | | | | |
| Unless otherwise specified, use tolerance +/-0,25% | | | | | |
| Change Drawing with CAD only | | | | | |
| Description | | | B6 - 400x150x118 | | |
| SZ-LV-Draft | | | Article No. | 0000.000 | Sheet 2 |
| Drawing No. | Revision | Model No. | SAS 0000 | | |

